



Dati tecnici - Technical data

Applicazioni - Applications	Circuiti pneumatici, oleodinamici e idraulici Pneumatic and hydraulic systems
Pressione di lavoro - Working pressure	vuoto + 18 bar - vacuum + 18 bar
Range di temperatura - Temperature range	Vedi caratteristiche dei tubi impiegati See features hose used
Tubi consigliati - Recommended hoses	Nylon, Poliuretano o Rilsan - Nylon, Polyurethane or Rilsan

Guida alle referenze
Guide to references

312 . 01 . 04 . 18

Serie
Line312 = Raccordo
a calzamento
Quick fittingTipo di raccordo
Fitting typeConsultare le tabelle alle
pagine che seguonoPlease check it in following
pagesFiletto
Thread Size18 = 1/8
14 = 1/4
38 = 3/8
12 = 1/2
M5 = M5∅ Tubo
Tube diameter04 = tubo 4/2,7 mm
06 = tubo 6/4 mm
08 = tubo 8/6 mm
10 = tubo 10/8 mm
12 = tubo 12/10 mm
15 = tubo 15/12,5 mm

Il raccordo a calzamento rimane ancora una valida alternativa al raccordo automatico in presenza di applicazioni particolarmente gravose.

The quick fitting remains a valid alternative to the push-in fitting in the presence of severe demanding applications.

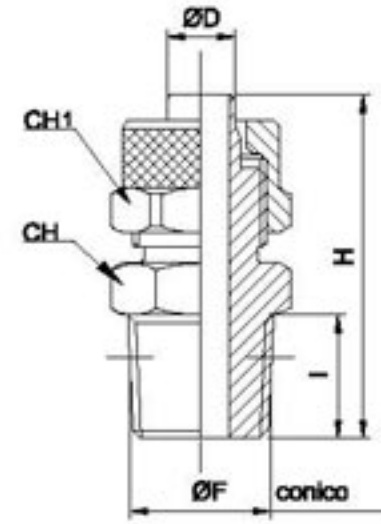
312.01Maschio diritto conico
Conical straight male

CODICE-CODE	D	F	I	H	CH	CH 1	Bag Qty
312.01.04.18	4/2,7	1/8	8	23,8	12	8	10
312.01.05.18	5/3	1/8	8	25	12	8	20
312.01.06.18	6/4	1/8	8	27,5	12	12	20
312.01.06.14	6/4	1/4	11	31	14	12	10
312.01.06.38	6/4	3/8	11,5	31,5	17	12	10
312.01.08.18	8/6	1/8	8	27,5	12	14	10
312.01.08.14	8/6	1/4	11	31	14	14	10
312.01.08.38	8/6	3/8	11,5	31,5	17	14	10
312.01.10.18	10/8	1/8	8	29,5	14	16	10
312.01.10.14	10/8	1/4	11	32,5	14	16	10
312.01.10.38	10/8	3/8	11,5	33	17	16	10
312.01.10.12	10/8	1/2	14	36	22	16	5
312.01.12.38	12/10	3/8	11,5	34,5	17	18	10
312.01.12.12	12/10	1/2	14	37,5	22	18	5
312.01.15.12	15/12,5	1/2	14	39,5	22	22	5

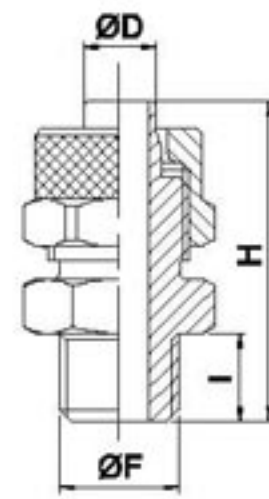
312.02Maschio diritto cilindrico
Cylindrical straight male

CODICE-CODE	D	F	I	H	CH	CH 1	Bag Qty
312.02.05.M5	5/3	M5	4	20	8	8	20
312.02.06.M5	6/4	M5	4	21	8	9	20
312.02.05.18	5/3	1/8	6	23	14	8	20
312.02.06.18	6/4	1/8	6	25,5	14	12	20
312.02.06.14	6/4	1/4	8	28	17	12	20
312.02.06.38	6/4	3/8	9	29	19	12	10
312.02.08.18	8/6	1/8	6	25,5	14	14	10
312.02.08.14	8/6	1/4	8	28	17	14	10
312.02.08.38	8/6	3/8	9	29	19	14	10
312.02.10.18	10/8	1/8	6	27	14	16	10
312.02.10.14	10/8	1/4	8	29,5	17	16	10
312.02.10.38	10/8	3/8	9	30,5	19	16	10
312.02.10.12	10/8	1/2	10	32	24	16	10
312.02.12.38	12/10	3/8	9	32	19	18	10
312.02.12.12	12/10	1/2	10	33,5	24	18	5
312.02.15.12	15/12,5	1/2	10	33,5	24	22	5

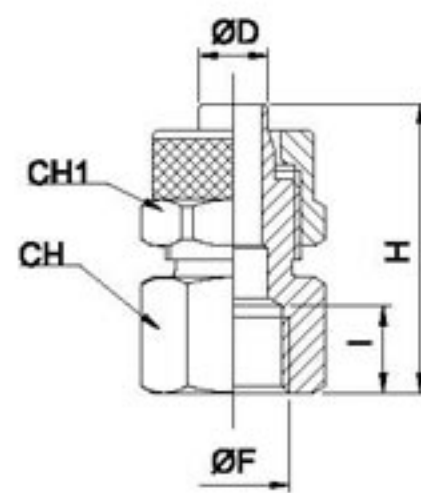
312.04Femmina diritta cilindrica
Cylindrical straight female

CODICE-CODE	D	F	I	H	CH	CH 1	Bag Qty
312.04.05.18	5/3	1/8	8	22,5	14	8	20
312.04.06.18	6/4	1/8	8	25	14	12	20
312.04.06.14	6/4	1/4	11	29	17	12	20
312.04.08.18	8/6	1/8	8	25	14	14	20
312.04.08.14	8/6	1/4	11	29	17	14	10
312.04.08.38	8/6	3/8	11,5	29,5	20	14	10
312.04.10.18	10/8	1/8	8	26,5	14	16	10
312.04.10.14	10/8	1/4	11	30,5	17	16	10
312.04.10.38	10/8	3/8	11,5	31	20	16	10
312.04.10.12	10/8	1/2	14	34,5	24	16	10
312.04.12.38	12/10	3/8	11,5	32,5	20	18	10

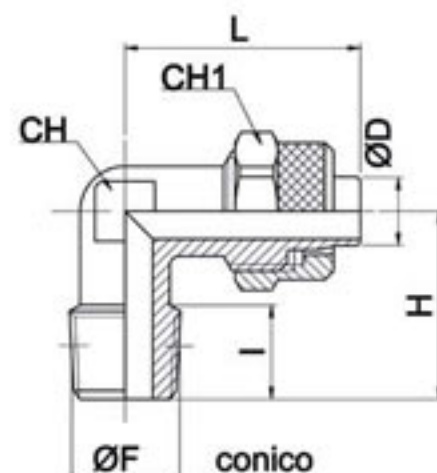
312.05Curva maschio cilindrica
Conical elbow male

CODICE-CODE	D	F	I	H	L	CH	CH 1	Bag Qty
312.05.04.M5	4/2,7	M5	4	15	19,5	8	8	10
312.05.04.18	4/2,7	1/8	8	17	19,5	8	8	10
312.05.05.18	5/3	1/8	8	17	21,5	8	8	20
312.05.06.18	6/4	1/8	8	17	22,5	8	12	20
312.05.06.14	6/4	1/4	11	20	22,5	10	12	10
312.05.06.38	6/4	3/8	11,5	22,5	23,5	11	12	10
312.05.08.18	8/6	1/8	8	17	22,5	10	14	10
312.05.08.14	8/6	1/4	11	20	22,5	10	14	10
312.05.08.38	8/6	3/8	11,5	22,5	24	11	14	10
312.05.10.18	10/8	1/8	8	18,5	25,5	11	16	10
312.05.10.14	10/8	1/4	11	21,5	25,5	11	16	10
312.05.10.38	10/8	3/8	11,5	22,5	25,5	11	16	10
312.05.12.38	12/10	3/8	11,5	24,5	30	14	18	10
312.05.12.12	12/10	1/2	14	28	30,5	17	18	5
312.05.15.12	15/12,5	1/2	14	28	34	17	22	5

312.06

Curva femmina cilindrica
Cylindrical elbow female

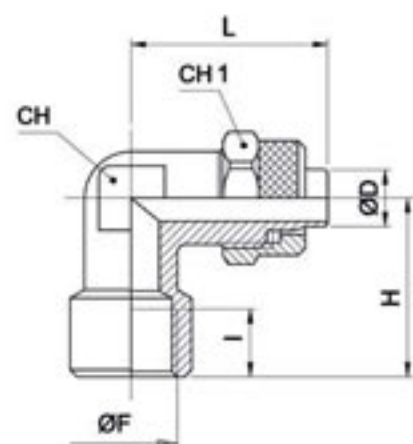

CODICE-CODE	D	F	I	H	L	CH	CH 1	Bag Qty
312.06.05.18	5/3	1/8	8	19	21,5	10	8	20
312.06.06.18	6/4	1/8	8	19	22,5	10	12	20
312.06.06.14	6/4	1/4	10,5	23	25	11	12	10
312.06.08.18	8/6	1/8	8	19	22,5	10	14	20
312.06.08.14	8/6	1/4	10,5	23	25	11	14	10
312.06.10.14	10/8	1/4	11	23,5	26	13	16	10
312.06.12.38	12/10	3/8	11,5	28	30,5	17	18	5

312.07

Curva maschio cilindrica girevole
Swivel elbow male with o-ring

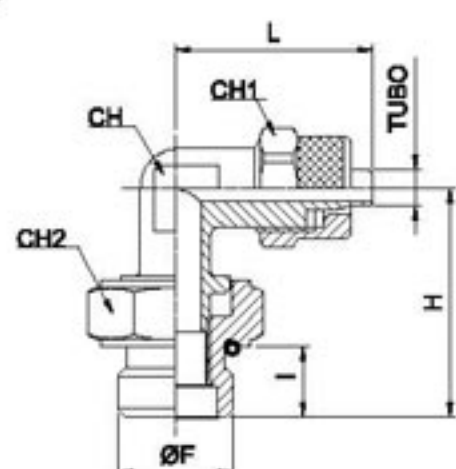

CODICE-CODE	D	F	I	H	L	CH	CH 1	CH 2	Bag Qty
312.07.06.18	6/4	1/8	6	22,5	22,5	8	12	14	10
312.07.06.14	6/4	1/4	8	25	23,5	10	12	17	10
312.07.08.18	8/6	1/8	6	22,5	23,5	10	14	14	10
312.07.08.14	8/6	1/4	8	25	23,5	10	14	17	10
312.07.10.14	10/8	1/4	8	25,5	23,5	11	14	17	10

312.09

T maschio centrale
"T" conical central male

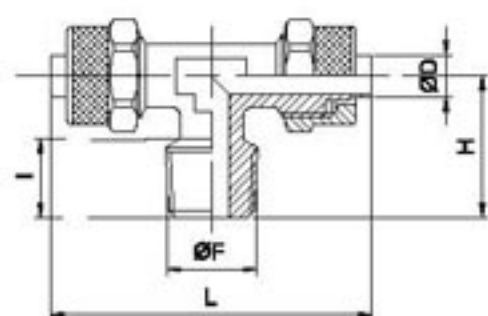

CODICE-CODE	D	F	I	H	L	CH	CH 1	Bag Qty
312.09.05.18	5/3	1/8	8	17	43	8	8	20
312.09.06.18	6/4	1/8	8	17	45	8	12	10
312.09.06.14	6/4	1/4	11	20,5	45,5	10	12	10
312.09.08.18	8/6	1/8	8	17,5	45,5	10	14	10
312.09.08.14	8/6	1/4	11	20,5	45,5	10	14	10
312.09.08.38	8/6	3/8	11,5	22,5	48	11	14	10
312.09.10.14	10/8	1/4	11	21,5	51	11	16	5
312.09.10.38	10/8	3/8	11,5	22,5	51	11	16	5
312.09.12.38	12/10	3/8	11,5	24,5	60	14	18	5
312.09.12.12	12/10	1/2	14	28	61	17	18	5
312.09.15.12	15/12,5	1/2	14	28	68	17	22	5

312.10

T maschio laterale
"T" conical lateral male

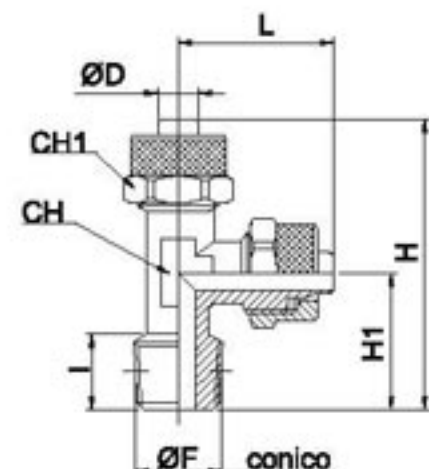

CODICE-CODE	D	F	I	H	H 1	L	CH	CH 1	Bag Qty
312.10.05.18	5/3	1/8	8	38,5	17	21,5	8	8	20
312.10.06.18	6/4	1/8	8	39,5	17	22,5	8	12	10
312.10.06.14	6/4	1/4	11	42,5	20	22,5	10	12	10
312.10.08.18	8/6	1/8	8	40,5	17,5	22,5	10	14	10
312.10.08.14	8/6	1/4	11	43,5	20,5	22,5	10	14	10
312.10.08.38	8/6	3/8	11,5	46,5	22,5	23,5	11	14	10
312.10.10.14	10/8	1/4	11	46,5	21	25,5	11	16	5
312.10.10.38	10/8	3/8	11,5	48	22,5	25,5	11	16	5
312.10.12.38	12/10	3/8	11,5	54,5	24,5	30	14	18	5
312.10.12.12	12/10	1/2	14	58,5	28	30,5	17	18	5
312.10.15.12	15/12,5	1/2	14	62	28	34	17	22	5

312.11

Diritto intermedio
Straight union

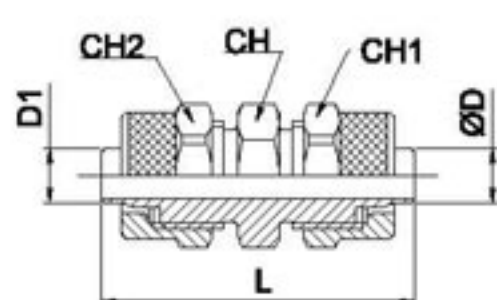

CODICE-CODE	D	D 1	L	CH	CH 1	CH 2	Bag Qty
312.11.05	5/3	5/3	28,5	8	8	8	20
312.11.06	6/4	6/4	34,5	12	12	12	20
312.11.08	8/6	8/6	35	14	14	14	10
312.11.08.06	8/6	6/4	35	14	14	12	10
312.11.10	10/8	10/8	38	14	16	16	10
312.11.12	12/10	12/10	41	17	18	18	5
312.11.15	15/12,5	15/12,5	45,5	22	22	22	5

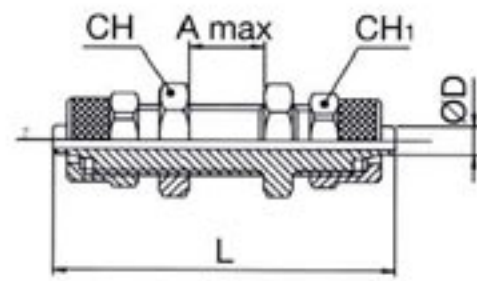
312.12Passaparete intermedio
Bulkhead union

CODICE-CODE	D	CH	CH 1	L	A max	Bag Qty
312.12.05	5/3	9	8	40	8,5	20
312.12.06	6/4	14	12	48	10,5	10
312.12.08	8/6	16	14	48	10,5	10
312.12.10	10/8	17	16	50	8,5	10
312.12.12	12/10	19	18	53	8,5	5
312.12.15	15/12,5	24	22	58	8,5	5

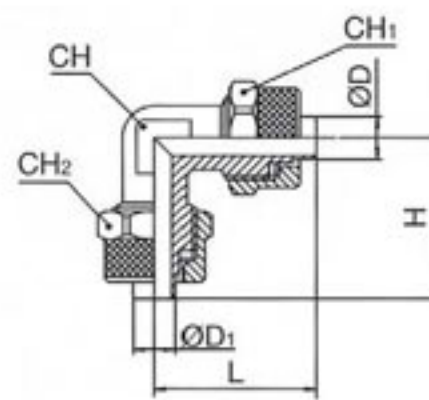
312.13Curva intermedia
Elbow union

CODICE-CODE	D	D 1	H	L	CH	CH 1	CH 2	Bag Qty
312.13.05	5/3	5/3	21,5	21,5	8	8	8	20
312.13.06	6/4	6/4	21,5	21,5	8	12	12	20
312.13.08	8/6	8/6	22,5	22,5	10	14	14	10
312.13.08.06	8/6	6/4	22,5	22,5	10	14	12	10
312.13.10	10/8	10/8	25,5	25,5	11	16	16	10
312.13.12	12/10	12/10	30	30	14	18	18	5
312.13.15	15/12,5	15/12,5	34	34	17	22	22	5

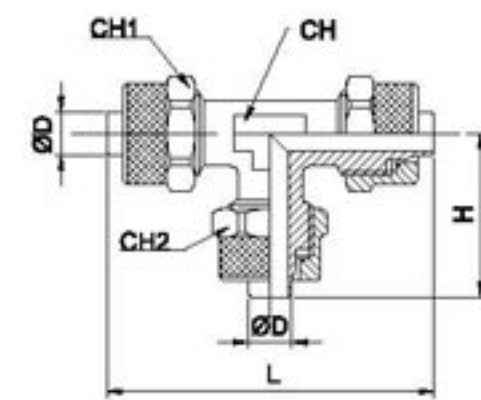
312.14T intermedio
"T" union

CODICE-CODE	D	D 1	H	L	CH	CH 1	CH 2	Bag Qty
312.14.05	5/3	5/3	21,5	43	8	8	8	20
312.14.06	6/4	6/4	22,5	45	8	12	12	10
312.14.08	8/6	8/6	22,5	45	10	14	14	10
312.14.08.06	8/6	6/4	22,5	45	10	14	12	10
312.14.10	10/8	10/8	25,5	51	11	16	16	5
312.14.12	12/10	12/10	30	60	14	18	18	5
312.14.15	15/12,5	15/12,5	34	68	17	22	22	5

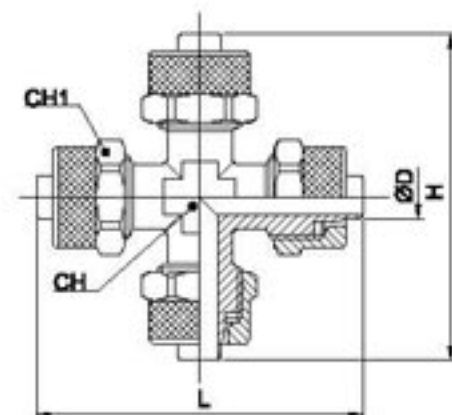
312.16Croce intermedia
Cross union

CODICE-CODE	D	H	L	CH	CH 1	Bag Qty
312.16.05	5/3	43	43	8	8	10
312.16.06	6/4	45	45	8	12	10
312.16.08	8/6	45	45	10	14	10
312.16.10	10/8	51	51	11	16	5

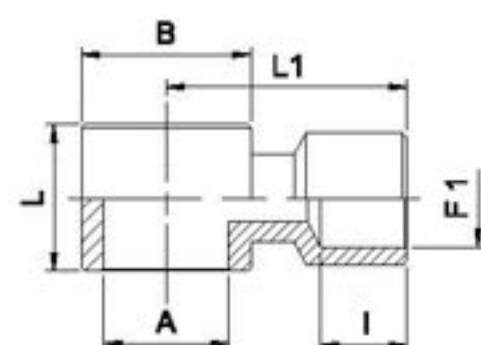
312.23Anello femmina
Female banjo

CODICE-CODE	F	F 1	I	H	L	Bag Qty
312.23.18	1/8	1/8	8	14,5	20	10
312.23.14	1/4	1/4	10	17,5	24,5	10

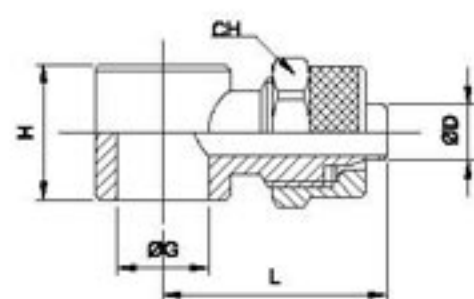
312.17Anello singolo
Single banjo

CODICE-CODE	D	F	H	L	CH 1	Bag Qty
312.17.04.M5	4/2,7	M5	9	15,8	8	10
312.17.04.18	4/2,7	1/8	14,5	21,3	8	10
312.17.05.M5	5/3	M5	9	17	8	10
312.17.05.18	5/3	1/8	14,5	22,5	8	20
312.17.06.M5	6/4	M5	9	18	9	20
312.17.06.18	6/4	1/8	14,5	24	12	10
312.17.06.14	6/4	1/4	14,5	26	12	10
312.17.08.18	8/6	1/8	14,5	24	14	10
312.17.08.14	8/6	1/4	14,5	26	14	10
312.17.10.14	10/8	1/4	14,5	27,5	16	10

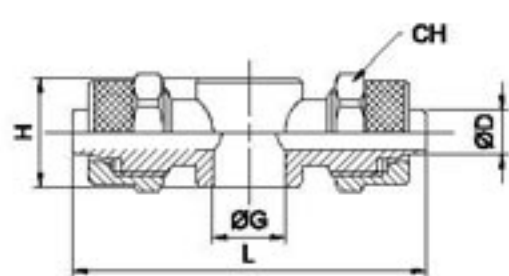
312.18Anello doppio
Double banjo

CODICE-CODE	D	F	H	L	CH 1	Bag Qty
312.18.04.18	4/2,7	1/8	14,5	42,6	8	10
312.18.05.18	5/3	1/8	14,5	45	8	10
312.18.06.18	6/4	1/8	14,5	48	12	10
312.18.06.14	6/4	1/4	14,5	52	12	10
312.18.08.18	8/6	1/8	14,5	48	14	10
312.18.08.14	8/6	1/4	14,5	52	14	10
312.18.10.14	10/8	1/4	14,5	55	16	5

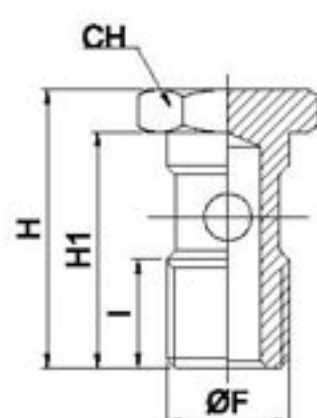
312.19Vite cava singola
Single screw

CODICE-CODE	F	I	H	H 1	CH 1	Bag Qty
312.19.M5	M5	6	18	14,5	8	10
312.19.18	1/8	8	27	23	14	20
312.19.14	1/4	11	29,5	25	17	10

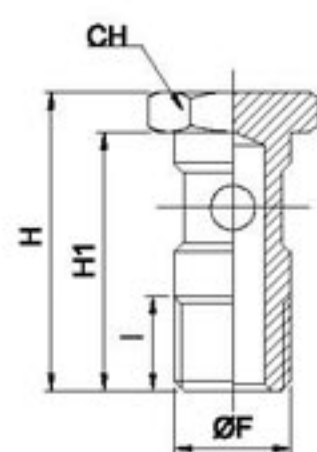
312.20Vite cava singola lunga
Longer single screw

CODICE-CODE	F	I	H	H 1	CH 1	Bag Qty
312.20.18	1/8	8	31	27	14	20
312.20.14	1/4	11	33,5	29	17	10

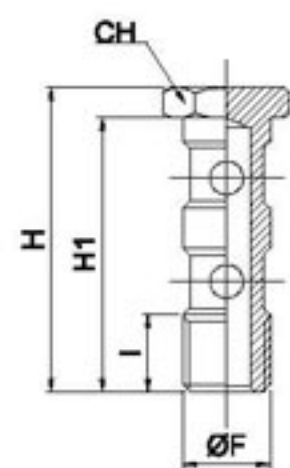
312.21Vite cava doppia
Double screw

CODICE-CODE	F	I	H	H 1	CH 1	Bag Qty
312.21.18	1/8	8	43	39	14	10
312.21.14	1/4	11	45,5	41	17	10

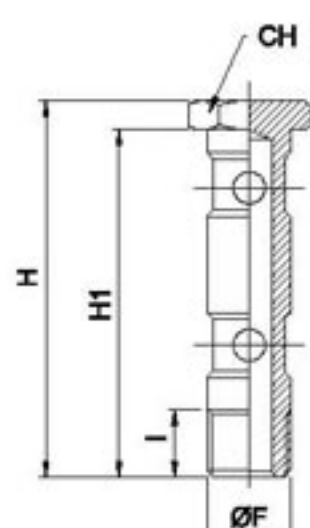
312.22Vite cava doppia lunga
Longer double screw

CODICE-CODE	F	I	H	H 1	CH 1	Bag Qty
312.22.18	1/8	8	56	52	14	10
312.22.14	1/4	11	58,5	54	17	10

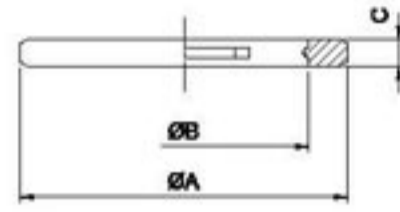
312.25Rondella in plastica
Indented nylon washer

CODICE-CODE	type	A	B	C	Bag Qty
312.25.M5	M5	8	5,2	1,3	10
312.25.18	1/8	14	10	1,5	20
312.25.14	1/4	18	13,5	1,5	20

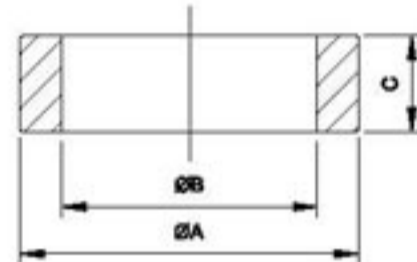
312.28Rondella alta in plastica
5mm sealing ring

CODICE-CODE	type	A	B	C	Bag Qty
312.28.18	1/8	14	10	5	10
312.28.14	1/4	17,5	13,2	5	10

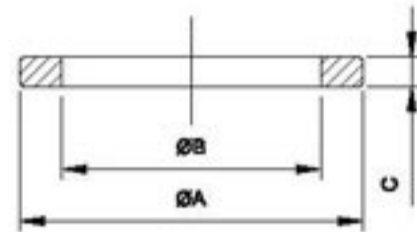
312.26Rondella in nylon
Nylon washer

CODICE-CODE	type	A	B	C	Bag Qty
312.26.M5	M5	8,5	5	1,5	10
312.26.18	1/8	14	9,8	1,5	20
312.26.14	1/4	18	13,2	1,5	20

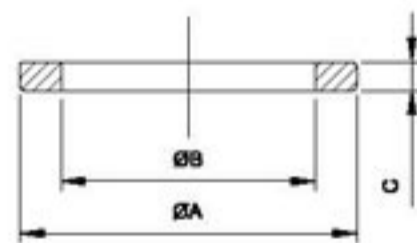
312.27Rondella in alluminio
Aluminium washer

CODICE-CODE	Type	A	B	C	Bag Qty
312.27.18	1/8	14	10	1,5	20
312.27.14	1/4	17,3	13,3	1,5	20

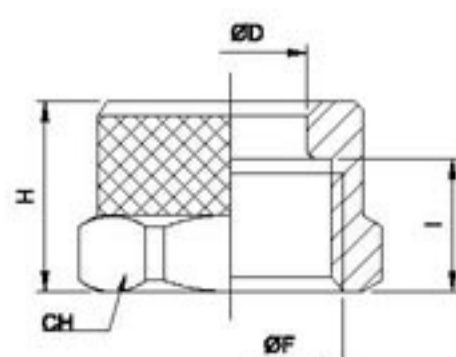
312.29Dado di bloccaggio
Locking nut

CODICE-CODE	D	F	I	H	CH	Bag Qty
312.29.04	4/2,7	M6X0,5	6	8,1	8	10
312.29.05	5/3	M7X0,75	6	8,5	8	10
312.29.06.M8	6/4	M8X0,75	6,5	9	9	20
312.29.06M10	6/4	M10X1	7,5	10,5	12	20
312.29.08	8/6	M12X1	7,5	10,5	14	20
312.29.10	10/8	M14X1	8	11,5	16	20
312.29.12	12/10	M16X1	10	13	18	10
312.29.15	15/12,5	M20X1	11	15,5	22	10