

Line

250 ø32÷100mm

Cilindri ISO 15552 (ISO 6431)

Cylinders ISO 15552 (ISO 6431)



Dati Tecnici - Technical data

Fluido - Fluid	Aria filtrata con o senza lubrificazione - Filtered air with or without lubrication	
Temperatura d'esercizio - Working temperature	0°C (-20°C con aria secca)+70°C - 0°C (-20°C with dry air)+70°C	
Pressione massima d'esercizio - Max. working pressure	max. 10 Bar (max. 1,00 MPa)	
Lubrificazione - Lubrication	se si utilizza aria lubrificata, la lubrificazione deve essere continua in case of lubricated air, the lubrication should never be interrupted	
Materiali - Materials	Camicia: alluminio anodizzato Stelo: acciaio Inox AISI 303/Acciaio cromato Testate: tecnopolimero termoplastico Pistone: resina acetaleica Connessioni filettate: inserto in ottone	Barrel: anodized aluminium Piston rod: AISI 303 stainless steel/Chromed steel Heads: technopolymer Piston: acetalic resin Threaded connections: brass insert

Corse standard - Standard strokes (mm)

Alesaggio - Bore size	25	50	80	100	125	160	200	250	300	320	350	400	450	500	600	700	800	900	1000
32	▲	▲	▲	▲	▲	▲	▲	▲	▲	▲	▲	▲	▲	▲	▲	▲	▲	▲	▲
40	▲	▲	▲	▲	▲	▲	▲	▲	▲	▲	▲	▲	▲	▲	▲	▲	▲	▲	▲
50	▲	▲	▲	▲	▲	▲	▲	▲	▲	▲	▲	▲	▲	▲	▲	▲	▲	▲	▲
63	▲	▲	▲	▲	▲	▲	▲	▲	▲	▲	▲	▲	▲	▲	▲	▲	▲	▲	▲
80	▲	▲	▲	▲	▲	▲	▲	▲	▲	▲	▲	▲	▲	▲	▲	▲	▲	▲	▲
100	▲	▲	▲	▲	▲	▲	▲	▲	▲	▲	▲	▲	▲	▲	▲	▲	▲	▲	▲

Codici di ordinazione Order codes

C250 DE 032 0050 M I P

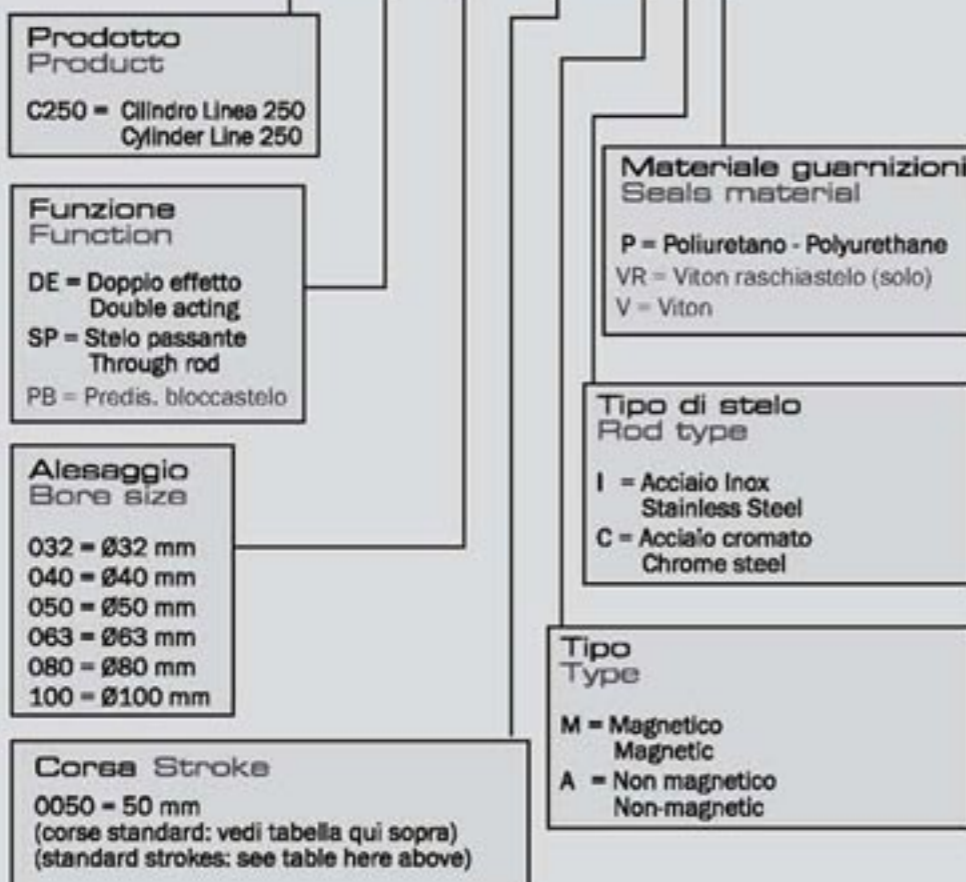

I cilindri della linea 250, grazie all'accurata scelta dei materiali impiegati e al design particolarmente pulito, sono indicati per gli ambienti sporchi e polverosi per l'elevata facilità d'esecuzione delle operazioni di pulizia.

I cilindri pneumatici di questa linea sono caratterizzati da testate in tecnopolimero termoplastico ad alta resistenza e da una camicia in alluminio anodizzato a profilo quadro "S25" con quattro cave per l'alloggiamento a scomparsa del sensore.

Cylinders Line 250, owing to the careful selection of raw materials and definitely clean design, are suitable for applications in dirty and dusty environments thanks to the great easiness of cleaning operations. Pneumatic Cylinders Line 250 are distinguished by heads in high-resistance thermoplastic technopolymer and a square profile barrel in anodized aluminium "S25" having four slots for housing the foldaway magnetic switch.

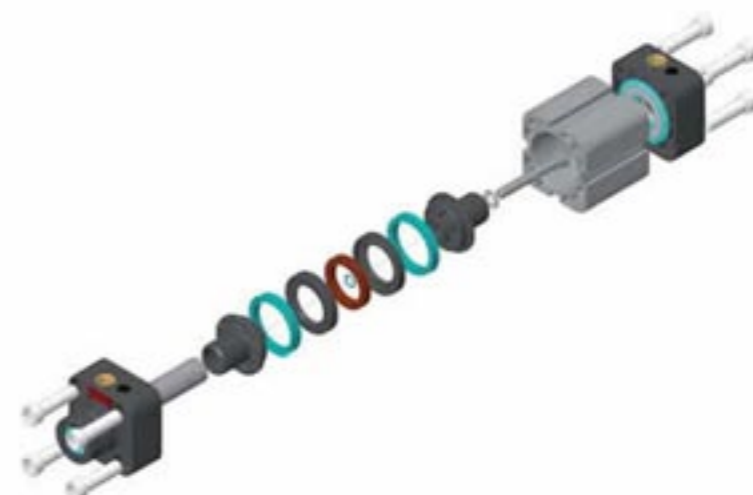

Line

250 $\varnothing 32:100\text{mm}$ Cilindri ISO 15552 (ISO 6431) Cylinders ISO 15552 (ISO 6431)



Cilindro Linea 250
Cylinder Line 250

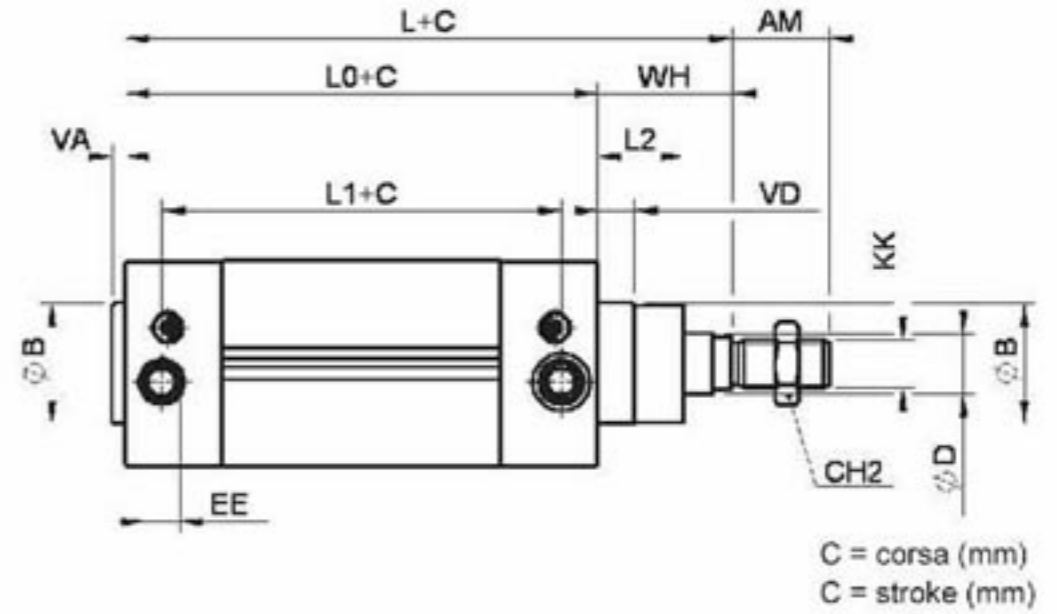
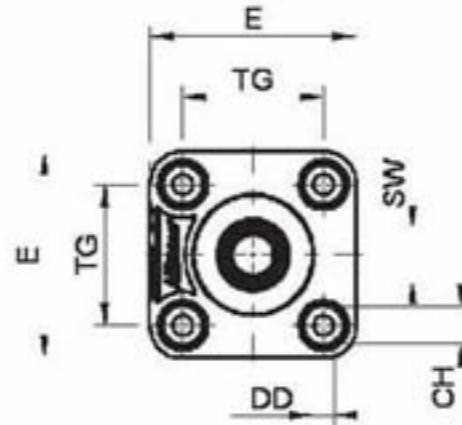

Corse standard - Standard strokes (mm)

Ø	AM	ØB	CH	CH1	CH2	ØD	DD	E	EE	KK	L	L0	L1	L2	SW	TG	VA	VD	WH
32	22	30	8	10	17	12	M6	50	G1/8"	M10x1,25	120	94	69	19	10	32,5	4	10,5	26
40	24	35	8	13	19	16	M6	55	G1/4"	M12x1,25	135	105	81	21,5	38	38	4	11	30
50	32	40	12	17	24	20	M8	68	G1/4"	M16x1,5	143	106	82	28,5	46,5	46,5	4	12,5	37
63	32	45	12	17	24	20	M8	79	G3/8"	M16x1,5	158	121	93	28,5	56,5	56,5	4	12,5	37
80	40	45	14	22	30	25	M10	98	G3/8"	M20x1,5	174	128	90	34	72	72	4	17	46
100	40	55	14	22	30	25	M10	115	G1/2"	M20x1,5	189	138	100	37,5	89	89	4	17	51

Cilindro Linea 250 - stelo passante
Cylinder Line 250 - through rod

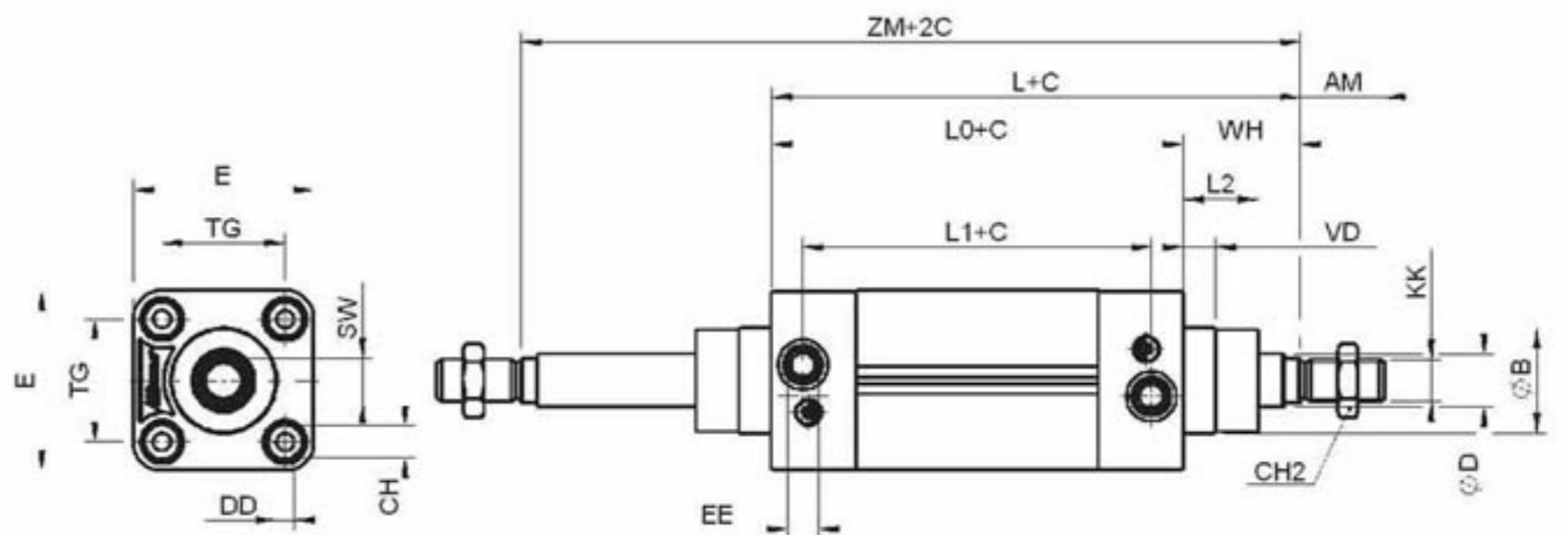

Corse standard - Standard strokes (mm)

Ø	AM	ØB	CH	CH2	ØD	DD	E	EE	KK	L	L0	L1	L2	SW	TG	VD	WH	ZM
32	22	30	8	17	12	M6	50	G1/8"	M10x1,25	120	94	69	19	10	32,5	10,5	26	146
40	24	35	8	19	16	M6	55	G1/4"	M12x1,25	135	105	81	21,5	13	38	11	30	165
50	32	40	12	24	20	M8	68	G1/4"	M16x1,5	143	106	82	28,5	17	46,5	12,5	37	180
63	32	45	12	24	20	M8	79	G3/8"	M16x1,5	158	121	93	28,5	17	56,5	12,5	37	195
80	40	45	14	30	25	M10	98	G3/8"	M20x1,5	174	128	90	34	22	72	17	46	220
100	40	55	14	30	25	M10	115	G1/2"	M20x1,5	189	138	100	37,5	22	89	17	51	240

Cerniera femmina
Female hinge

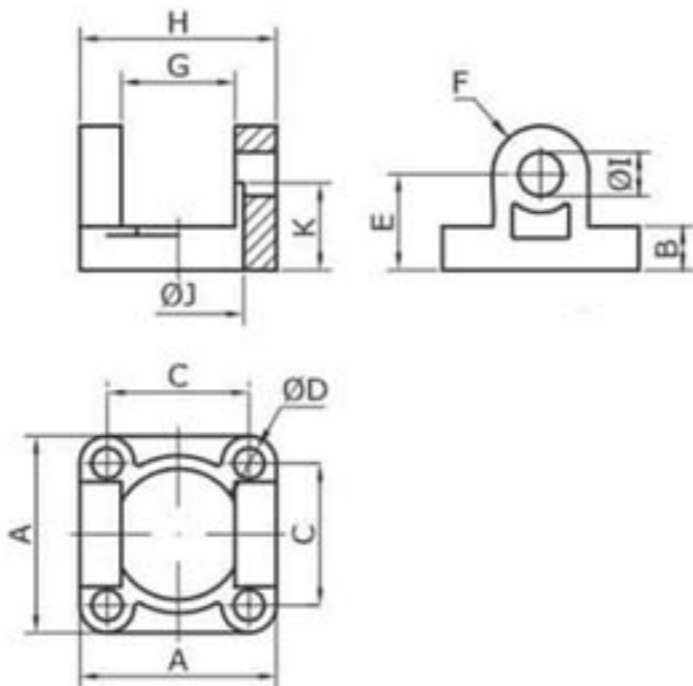

Dimensioni - Dimensions (mm)

CODE	\varnothing	A	B	C	$\varnothing D$	E	F	G	H	$\varnothing I$ (H11)	$\varnothing J$ (B13)	K	COD. PERNO PIN CODE
230A032001	32	45	10	32,5	7	22	11	26	45	10	30	20	230A032010
230A040001	40	52	10	38	7	25	13	28	52	12	35	22	230A040010
230A050001	50	65	12	46,5	9	32	13	32	60	12	40	29	230A050010
230A063001	63	75	12	56,5	9	36	17	40	70	16	45	29	230A063010
230A080001	80	95	16	72	11	41	17	50	90	16	45	-	230A080010
230A100001	100	115	16	89	± 1	50	21	60	110	20	55	-	230A100010
230A125001	125	140	20	110	14	50	26	70	130	25	60	-	230A125010
230A160001	160	180	20	140	18	55	31	90	170	30	65	-	230A160010
230A200001	200	220	25	175	18	60	31	90	170	30	75	-	230A200010

Le cerniere vengono fornite senza perno.
Per il codice del perno, vedi tabella.

Hinges are supplied without pin.
For pin code, please see table.

Controcerniera squadra base quadrata
Counter-hinge square basis

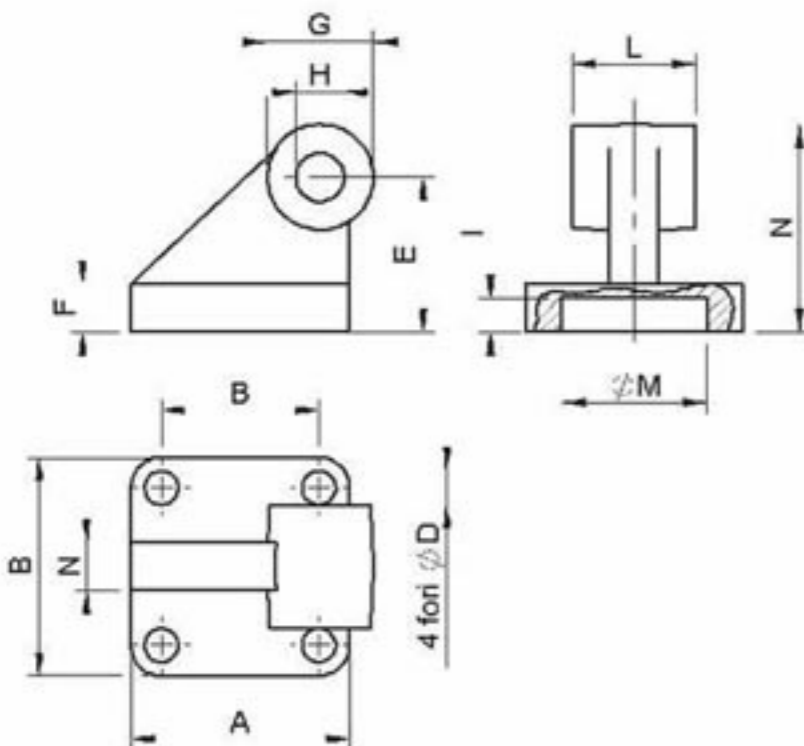

Dimensioni - Dimensions (mm)

CODE	\varnothing	A	B	C	$\varnothing D$	E	F	G	H	I	L	$\varnothing M$	N
230A032002	32	45	32,5	10	7	32	10	22	10	7	25,5	30	43
230A040002	40	52	38	12	7	36	10	26	12	7	27,5	35	49
230A050002	50	65	46,5	12	9	45	12	26	12	7	31,5	40	58
230A063002	63	75	56,5	15	9	50	12	34	16	7	39,5	45	67
230A080002	80	95	72	15	11	63	16	34	16	9	49,5	45	80
230A100002	100	115	89	22	11	73	16	42	20	9	59,5	55	94

Controcerniera squadra base rettangolare
Counter-hinge rectangular basis

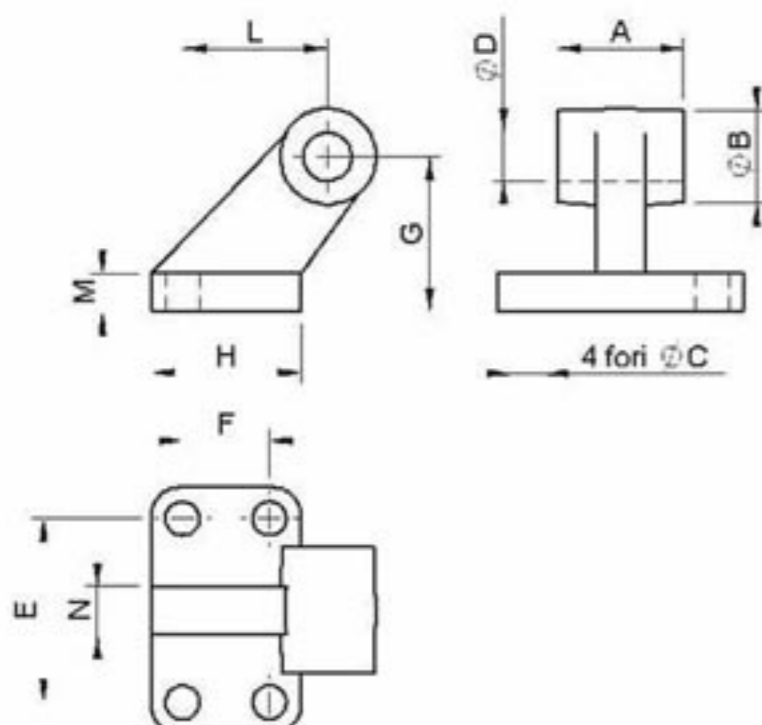

Dimensioni - Dimensions (mm)

CODE	\varnothing	A	$\varnothing B$	$\varnothing C$	$\varnothing D$	E	F	G	H	I	L	M	N
240A032006	32	26	20	7	10	38	18	32	31	51	21	8	10
240A040006	40	28	22	7	12	41	22	36	35	54	24	10	12
240A050006	50	32	26	9	12	50	30	45	45	65	33	12	16
240A063006	63	40	30	9	16	52	35	50	50	67	37	12	16
240A080006	80	50	30	11	16	66	40	63	60	86	47	14	20
240A100006	100	60	38	11	20	76	50	71	70	96	55	15	20

Piedino
Foot

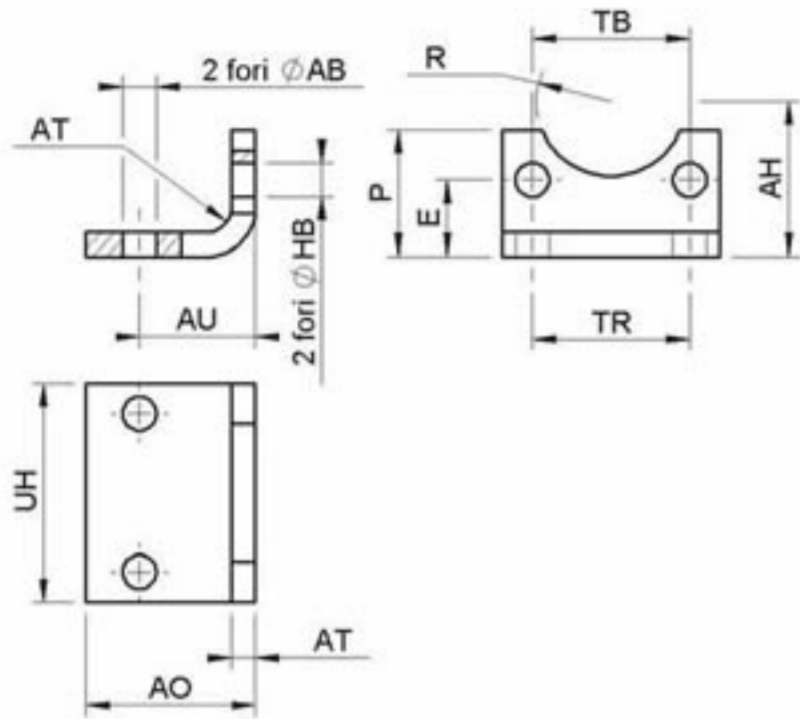

Dimensioni - Dimensions (mm)

CODE	\varnothing	AB	AH	AO	AT	AU	E	HB	P	R	TB	TR	UH
230A032003	32	7	32	35	4	24	15,75	7	26	15,5	32,5	32	45
230A040003	40	9	36	43	4	28	17	7	27	18	38	36	52
230A050003	50	9	45	47	4	32	21,75	9	35	20,5	46,5	45	65
230A063003	63	9	50	47	6	32	21,75	9	35	23	56,5	50	75
230A080003	80	12	63	61	6	41	27	11	46	23	72	63	95
230A100003	100	14	71	66	6	41	26,5	11	48	28	89	75	115
230A125003	125	16	90	60	8	45	35	13	80	31	110	90	140
230A160003	160	18	115	80	10	60	45	17	100	33	140	115	180
230A200003	200	22	135	100	12	70	47,5	17	120	38	175	135	220

Cerniera maschio
Male hinge

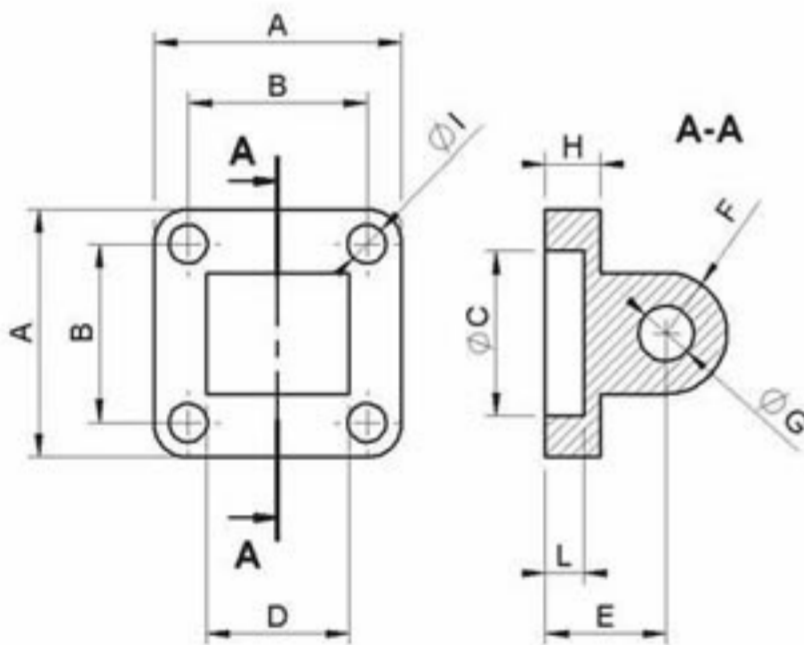

Dimensioni - Dimensions (mm)

CODE	\varnothing	A	B	C	D	E	F	G	H	I	L	COD. PERNO PIN CODE
230A032004	32	45	32,5	30	26	22	11	10	10	7	7	230A032010
230A040004	40	52	38	35	28	25	13	12	10	7	7	230A040010
230A050004	50	65	46,5	40	32	27	13	12	12	9	7	230A050010
230A063004	63	75	56,5	45	40	32	17	16	12	9	7	230A063010
230A080004	80	95	72	45	50	36	17	16	16	11	9	230A080010
230A100004	100	115	89	55	60	41	21	20	16	11	9	230A100010
230A125004	125	140	110	60	70	50	26	25	20	14	9	230A125010
230A160004	160	180	140	65	90	55	31	30	20	18	9	230A160010
230A200004	200	220	175	75	90	60	31	30	25	18	11	230A200010

Le cerniere vengono fornite senza perno.
Per il codice del perno, vedi tabella.

Hinges are supplied without pin.
For pin code, please see table.

Cerniera a snodo (DIN 648-K)
Swivel hinge (DIN 648-K)

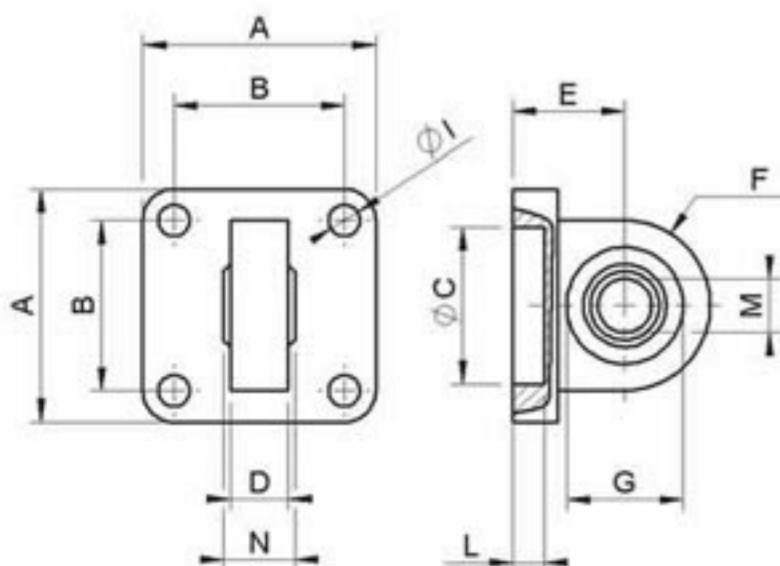

Dimensioni - Dimensions (mm)

CODE	\varnothing	A	B	C	D	E	F	G	H	I	L	M	N
230A032005	32	45	32,5	30	10,5	22	16	22	10	7	7	10	14
230A040005	40	52	38	35	12	25	19	26	10	7	7	12	16
230A050005	50	65	46,5	40	12	27	19	26	12	9	7	12	16
230A063005	63	75	56,5	45	15	32	24	32	12	9	7	16	21
230A080005	80	95	72	45	15	36	24	32	16	11	9	16	21
230A100005	100	115	89	55	18	41	30	40	16	11	9	20	25
230A125005	125	140	110	65	22	50	36	47	20	14	9	25	31
230A160005	160	180	140	65	25	55	36	55	20	18	9	30	37
230A200005	200	220	175	75	25	60	36	55	25	18	11	30	37

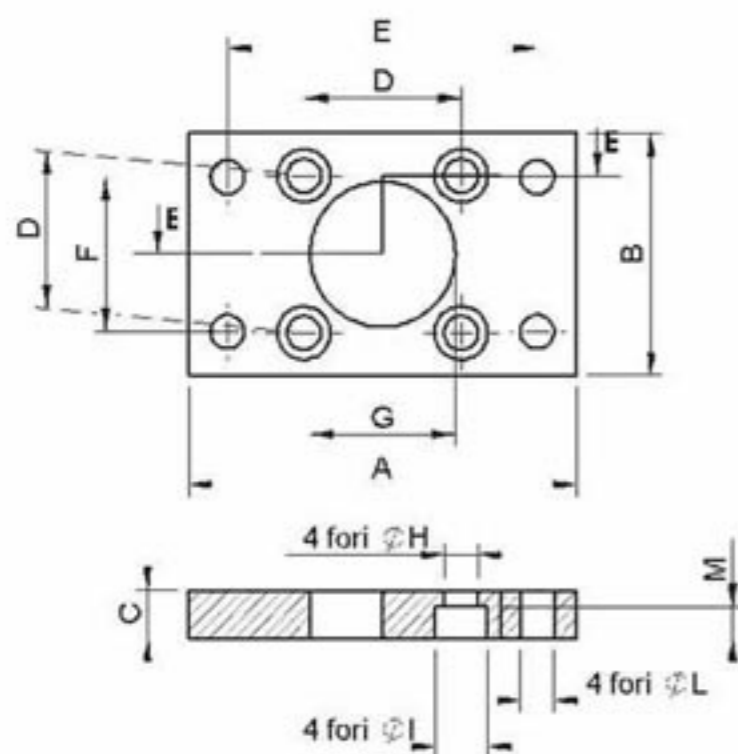
Flangia di fissaggio ISO
ISO fixing flange

Dimensioni - Dimensions (mm)

CODE	Ø	A	B	C	D	E	F	G	H	I	L	M
240A032001	32	80	50	10	32,5	64	32	30	7	11	7	6,5
240A040001	40	90	55	10	38	72	36	35	7	11	9	6,5
240A050001	50	110	65	12	46,5	90	45	40	9	15	9	8,5
240A063001	63	120	75	12	56,5	100	50	45	9	15	9	8,5
240A080001	80	150	95	15	72	126	63	45	11	18	12	10,5
240A100001	100	178	115	15	89	150	75	55	11	18	14	10,5
240A125001	125	220	140	20	110	180	90	60	13	20	16	12,5
240A160001	160	270	180	20	140	230	115	65	17	25	18	17
240A200001	200	312	225	25	175	270	135	75	17	25	22	17

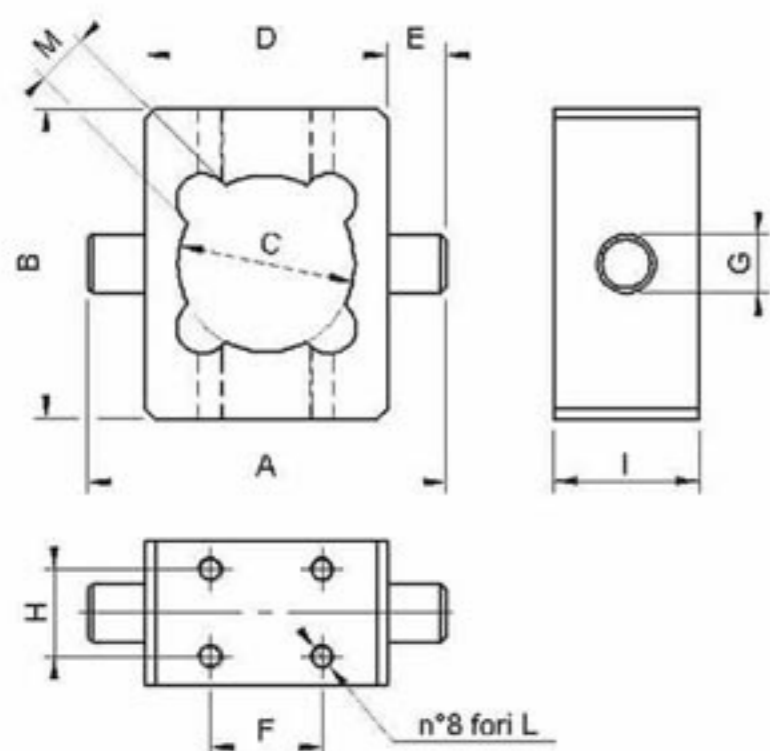
Cerniera intermedia Linea 240
Centre hinge Line 240

Dimensioni - Dimensions (mm)

CODE	Ø	A	B	C	D	E	F	G	H	I	L	M
240A032010	32	74	64	36,5	50	12	23	12	18	30	M5	11
240A040010	40	95	70	46	63	16	29	16	18	30	M5	11
240A050010	50	105	80	55,5	73	16	37	16	18	30	M5	14
240A063010	63	130	106	68,5	90	20	47	20	23	40	M6	14
240A080010	80	148	120	86,5	108	20	58	20	23	40	M6	15,5
240A100010	100	181	155	107	130	25	72	25	28	50	M8	16,5

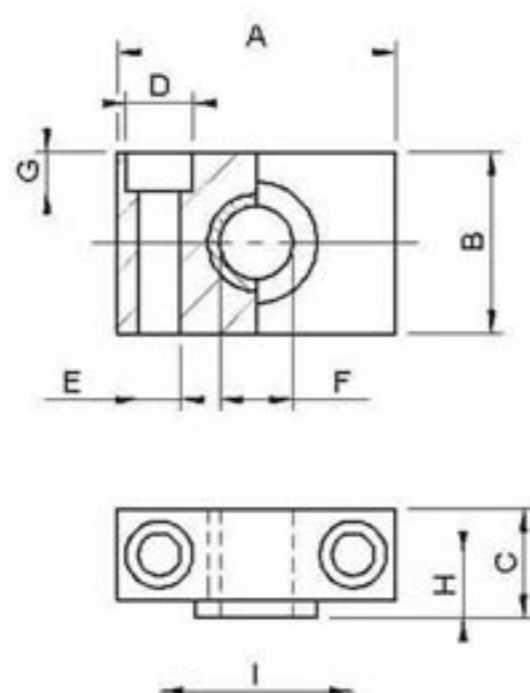
Kit snodi per cerniera intermedia
Joint kit centre hinge

Dimensioni - Dimensions (mm)

CODE	Ø	A	B	C	D	E	F	G	H	I
240A032011	32	46	30	18	11	7	12	6,5	10,5	32
240A040011	40-50	55	36	21	15	9	16	8,5	12	3
240A063011	63-80	65	40	23	18	11	20	10,5	13	42
240A100011	100	75	50	28,5	20	13	25	12,5	16	50

N.B.: Il kit é comprensivo di n°2 snodi per cerniera intermedia
N.B.: Kit includes n°2 joints for centre hinge

Giunto a snodo Swivel joint

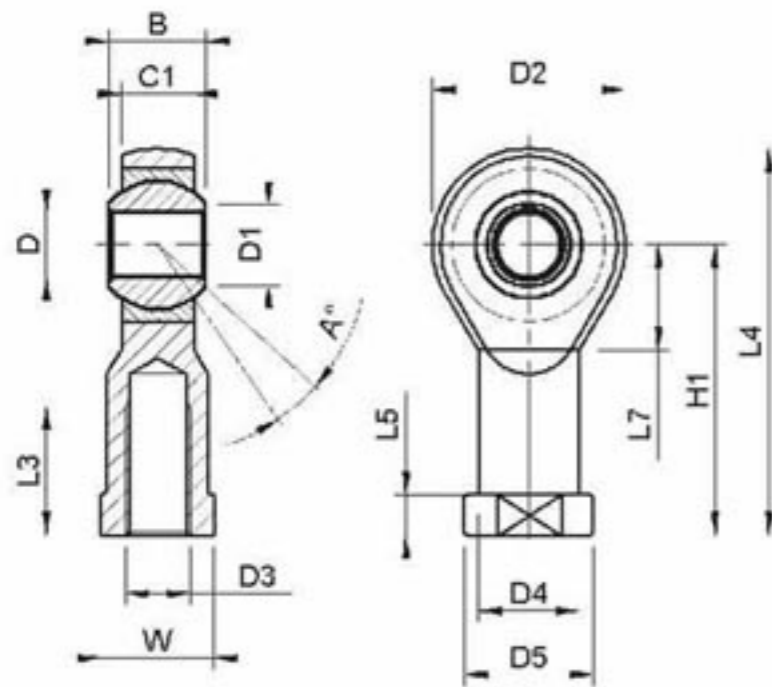

Dimensioni - Dimensions (mm)

CODE	Ø	B	C1	D	D1	D2	D3	D4	D5	DK	H1	L3	L4	L5	L7	W
240A032004	32	14	10,5	10	12,9	28	M10	15	19	19,05	43	20	57	6,5	15	17
240A040004	40	16	12	12	15,4	32	M12	17,5	22	22,22	50	22	66	6,5	17	19
240A050004	50-63	21	15	16	19,3	42	M16	22	27	28,57	64	28	85	8	23	22
240A080004	80-100	25	18	20	24,3	50	M20	27,5	34	34,92	77	33	102	10	27	30
240A125004	125	37	25	30	34,8	67	M27	40	50	50,80	110	51	144	15	36	41
240A160004	160-200	43	28	35	37,7	80	M36	46	58	57,15	125	53	165	17	41	50

Forcelle Rod forks

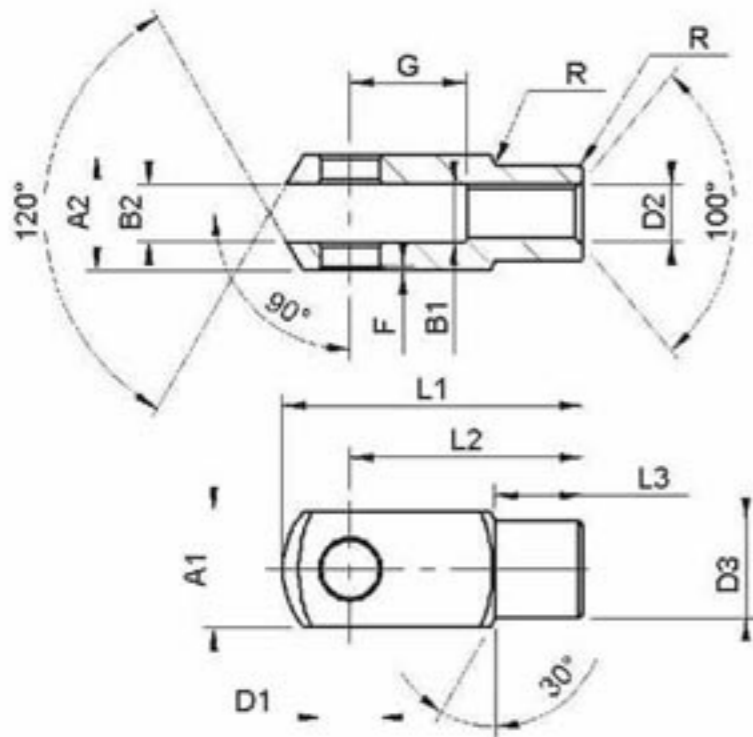

Dimensioni - Dimensions (mm)

CODE	Ø	A1	A2	B1	B2	D1	D2	D3	F	G	L1	L2	L3	R
240A032002	32	20	20	10	10	10	M10x1,25	18	0,5	20	52	40	15	0,5
240A040002	40	24	24	12	12	12	M12x1,25	20	0,5	24	62	48	18	0,5
240A050002	50-63	32	32	16	16	16	M16x1,50	26	1,0	32	83	64	24	1,0
240A080002	80-100	40	40	20	20	20	M20x1,50	34	1,0	40	105	80	30	1,0
240A125002	125	55	55	30	30	30	M27x2,00	48	1,0	54	148	110	38	1,0
240A160002	160-200	70	70	35	35	35	M36x2,00	60	1,0	72	188	144	40	1,0

Clips Clips

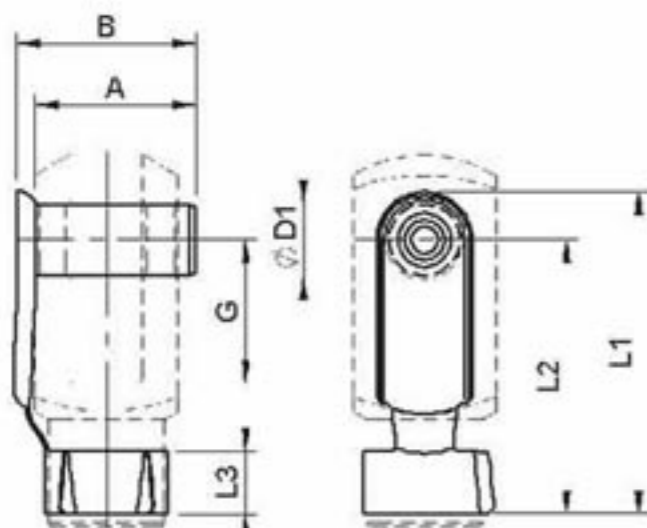

Dimensioni - Dimensions (mm)

CODE	Ø	A	B	D1	G	L1	L2	L3
240A032003	32	23	26,0	10	20	46	39	10
240A040003	40	28	32,0	12	24	55	47	12
240A050003	50-63	36	40,0	16	32	72	62	14
240A080003	80-100	44	48,0	20	40	88	72	16
240A125003	125(perno completo di seeger - pin complete with seeger)							
240A160003	160-200(perno completo di seeger - pin complete with seeger)							

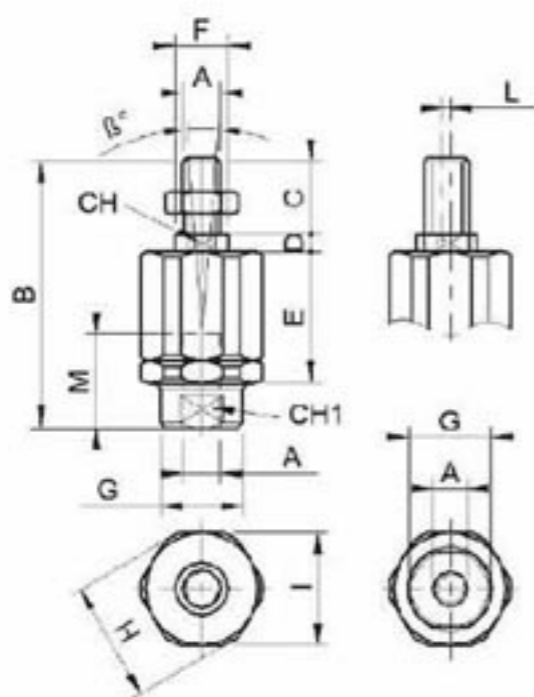
Giunto autoallineante
Self aligning joint

Dimensioni - Dimensions (mm)

CODE	\varnothing	A	B	C	D	E	F	G	H	I	L	M	CH	CH1	B°
240A032007	32	M10x1,25	71	20	5	35	14	22	32	30	2	20	12	19	10
240A040007	40	M12x1,25	75	24	5	35	14	22	32	30	2	20	12	19	10
240A050007	50-63	M16x1,5	103	32	8	54	22	32	45	41	2	32	20	30	10
240A080007	80-100	M20x1,5	119	40	8	54	22	32	45	41	2	40	20	30	10

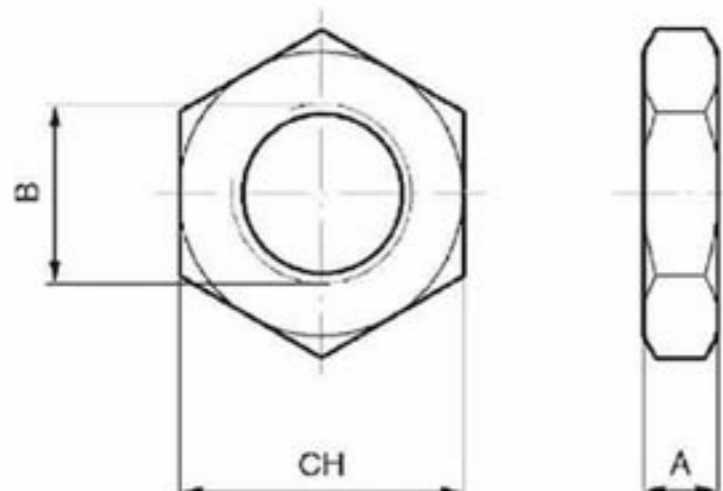
Dado per stelo ISO 15552
Nut for piston rod ISO 15552

Dimensioni - Dimensions (mm)

CODE	\varnothing	A	B	CH
240A032013	32	6	M10x1,25	17
220A008004	40	7	M12x1,25	19
220A012004	50-63	8	M16x1,25	24
240A080013	80-100	9	M20x1,5	30
240A125013	125	12	M27x2	41
240A160013	160-200	14	M36x2	55

Sensori
Magnetic Switches

Per i codici e i dati tecnici dei sensori consultare le pagine 45-46
For codes and technical data of magnetic switches please see pages 45-46